

Review of Housing Vulnerability

Implications for Climate Resilient Houses

AUTHORS

HUE UNIVERSITY

Doc. Candidate Tuan Anh Tran,
College of Sciences

Dr. Phong Tran,
College of Economics

Dr. Tran Huu Tuan,
College of Economics

ISET-INTERNATIONAL

Kate Hawley

DISCLAIMER FOR DISCUSSION PAPER

ISET-International's discussion papers contain preliminary research and findings. These products are disseminated to catalyze discourse on timely issues. Most discussion papers undergo revisions, and some will be published formally in a different format.

CITATION

Atta ur Rehman Sheikh, Sharmeen Malik, & Khan, F. (2013). Climate Resilient Housing: An Overview of the Policy Landscape in Pakistan. from Sheltering From a Gathering Storm No. 6. Institute for Social and Environmental Transition-International.

OVERVIEW

In developing countries, despite national governments and humanitarian agencies efforts to carry out plenty of recovery actions, most affected households still receive limited assistance (Suarez et al., 2008). In Vietnam, the government considers housing as one of the four most vulnerable sectors to climate extremes (MONRE, 2008) of which typhoons exhibit the greatest impact to housing in comparison to other climate hazards (Nhu et al., 2011). Recognized by the International Federation of Red Cross and Red Crescent Societies (IFRC), two of the four most dangerous natural hazards in the South East Asia are floods and typhoons in Vietnam (two others are tornado and flood-tide in East Timor) (IFRC, 2010). Floods and typhoons have frequently occurred in Philippines and Indonesia, but risk levels in these two countries are medium whereas higher levels of risk exist in Vietnam (IFRC, 2010) due to low levels of preparedness of Vietnamese vulnerable communities. In Vietnam, there has been a significant escalation in number of strong typhoons in recent years which makes it difficult to forecast their frequencies, their severity and their direction (MONRE, 2008). An estimated 80-90% of Vietnam's population is significantly affected by this kind of disaster (Vietnam-Government, 2007) where Central Vietnam is considered the most disaster-prone region of the country (Phong and Tinh, 2010).

Disaster is not just from natural origin since they are also triggered by vulnerable situations accumulated from unstable socio-economic, political and physical conditions and inadequate coping strategies. Inappropriate housing solutions together with poorly constructed houses have been known as one of the main sources of risks to climate hazards (Davis, 1978). To this extent, insecure structures are common with the lack of strong connections or attachments among building parts. In other cases, cultural inappropriateness of housing designs is more likely to dissatisfy beneficiaries who received disaster reconstruction

assistance and causes them to not apply for assistance in the future. Therefore, housing not only provides accommodation but also offers non-housing benefits for people in need (such as strong family stability, efficient homework and educational performances, family productivity, healthy living practices, economic development, etc.) (Fien et al., 2008).

The region of Central Vietnam is likely to be hit by at least two typhoons per year (Duy et al., 2007) & (Vietnam-Government, 2007) with a growing severity and frequency in the future. In Central Vietnam, one of the most important housing classifications in terms of disaster resilience was done by Development Workshop France (DWF) who grouped housing into three main types: solid, semi-solid, and temporary. However, results from the national census in 1999 and 2009 showed that confusion exists concerning the classification among building quality and building form. Instead, it was suggested by experts that housing should be categorized in four types according to the number of strong items in the building structure: permanent (kiên cố), semi-permanent (bán kiên cố), less permanent (thiếu kiên cố), and simple (đơn sơ). A permanent house comprises all three strong parts of building (foundation, walls, and roof). Semi- and less permanent consists of two and one strong part respectively. A simple house has no strong parts in its structure.

Da Nang is the most dynamically developed city of Central Vietnam where economic development and urbanisation is occurring strongly and rapidly. The GDP growth rate is always at the top, over 11% in recent years (Cu, 2008). According to national census in 2009, almost no less-permanent and simple houses exist in Da Nang (0.45% and 0.3% respectively) whereas semi-permanent housing covers the highest percentage of over 75%, followed by permanent housing with nearly 25%.

Da Nang's citizens experienced increased storm risk in recent years, especially after the typhoon Xangsane in 2006 which seriously destroyed the city. They employ various ways to respond to the storm events depending on their awareness and coping capacity, ranging from updating

disaster information, reinforcing their housing through the use of placing sandbags on roofs or attaching the roof to walls, and securing doors and windows (ADPC, 2007). In case of extremely strong typhoons, people are encouraged to move to safer places such as safer neighbour's houses or public buildings nearby. However, in reality, not all households move to safe places. For example, during typhoon Xangsane (2006) many households stayed in their weak homes and fought against strong winds by holding doors in place, anchoring the roof to a structure, or hiding under beds (ADPC, 2007). After the storms, repairing damaged houses, cleaning up properties, returning to their homes if evacuated, and informing local authorities about their housing and/or property damage are common actions conducted by the households.

Socio-economic situation of households translates to differing levels of housing vulnerability. For example, high income households often buy expensive plots in central urban areas with adequate urban infrastructure and public services, such as in the central districts of city or in central areas of districts. Their houses are therefore situated in safe or less vulnerable places to natural hazards. In addition, professionals (architects and engineers) or experienced builders strictly supervise housing construction to ensure that design and construction quality requirements are met. Houses of medium income families are more vulnerable than their high income counterparts since their structures usually do not incorporate enough connections or attachments for storm resistance. Furthermore, they are located in more vulnerable places. Due to very limited financial capacity, houses of low income households are the most vulnerable in comparison with the two groups discussed above because owners tend to buy the cheapest plots, usually far from the city centre, in suburban or peripheral zones or in hazard prone areas. In addition, their houses are very vulnerable without strong connections or bracings and often built based upon experiences of local masons without technical designs and construction supervision. In the aftermath of a typhoon, they have very limited socio-economic ability for recovery.

FIGURE 1: HOUSING TYPES

SIMPLE one without any RC parts

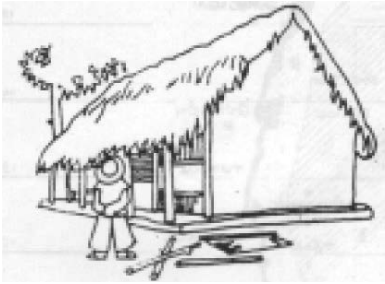

LESS PERMANENT with RC foundation only and non-RC walls and roof

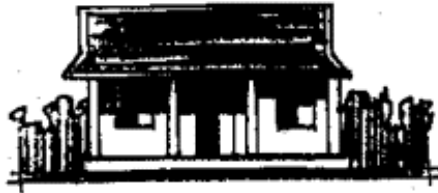

SEMI-PERMANENT with two parts by RC and one by non-RC (commonly roof part)

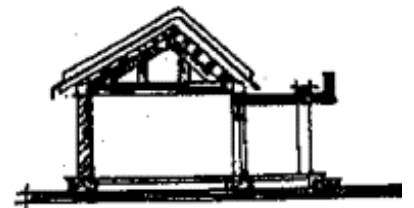
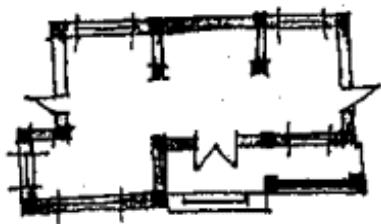

PERMANENT house with three strong parts made by reinforced concrete (RC)

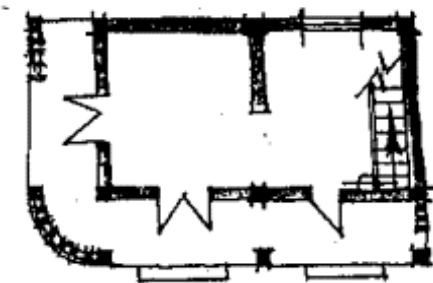

(CECI, 2003)

The common approach by applying one-size-fits-all solutions for geographically and culturally different regions in some housing projects recently may create more severity of post-disaster situations.



© S. Baker, Creative Commons, 2005

GAPS

One of the biggest problems of post-disaster housing reconstruction in developing countries is the exclusive attention to physical and visual aspects of reconstructing buildings with little consideration to people's ways of living (farming, crafting, etc.) and community's meanings, values, or traditions (Audefroy, 2010). The common approach by applying one-size-fits-all solutions for geographically and culturally different regions in some housing projects recently may create more severity of post-disaster situations (Esther, 2011). This problem is closely linked with the excessive reliance on foreign assistance who usually have inadequate understandings of local contexts and local cultures. This is mainly reflected in the inappropriate organisation of functional spaces, in housing styles and typology, and in improper uses of materials and construction techniques. Therefore, it can be implied that housing design without adequate local representation and cultural sensibility are very likely to create conflicts or even rejections from beneficiaries (Audefroy, 2010) and subsequently result in the ineffectiveness and unsuitability of rebuilt houses for future disasters.

In Central Vietnam, after the promulgation of *Doi moi* (socio-economic reform) policy in 1986 to change the national economy from the subsidized- to the market-orientation, households experienced remarkable economic

improvement with more financial investments spent on housing construction. Families began to use more durable and costly materials (cement blocks, fired bricks, steel bars, ceramic roof tiles, corrugated sheeting) instead of traditional ones (thatch, bamboo, leaf, timber) in their housing repair or construction (Norton and Chantry, 2008), but without adequate safety-related measures for disaster reduction in structures (Phong and Tinh, 2010). This failure has generated a so-called *two-fold source of vulnerability* (Norton and Chantry, 2008) in which the improper use of new materials unexpectedly lead to higher levels of risk of housing, and when a storm comes, greater damage is created that makes families come closer to poverty, one of the root causes of vulnerability (Wisner et al., 2004). More than 70 percent of residential houses built in this period do not incorporate typhoon- and flood-resistant features in their design and construction, of which, flat roofs, inadequate attachments of roofing sheets to underneath supporting structures, lack of structural bracings are common (Norton and Chantry, 2008).

In addition, most residential houses in central Vietnam have been built without technical guidance or instruction from professionals in terms of disaster resistance (CECI, 2003) and, as a result, they made housing sector more vulnerable to natural disasters. These create a rising tendency in housing

FIGURE 2: HOUSING DEVELOPMENT IN CENTRAL VIETNAM

With the accumulation of new risks to climate hazards due to inadequate apply of safety-related measures.



(The first three photos were taken by Tuan Anh Tran in 2011)

1980 >70%
Two-fold source vulnerability

© Liem, 2007

vulnerability to natural disasters in recent times, particularly in the extremely disaster prone region of central Vietnam.

There are several barriers to safe housing construction in Da Nang, related to the cost of disaster resistant measures, awareness of house owners, social pressures on owners, family financial capacity, and professional technical assistance. Additional costs of construction to follow disaster resistant principles always cover an amount of family budget that any households, especially for low-income ones, have to carefully consider whether or not using them in housing construction or renovation. This is not merely the financial problem of having sufficient or insufficient money to build, but also closely linked with social pressures and owner's awareness underneath. For examples, some households realize the importance of disaster resilient structure and have the financial means tend to extend more rooms or living space, or decorate buildings due to pressures from family members. In other cases of inadequate awareness on disaster preparedness, people expect to save money the most by reducing all additional items in construction including disaster resistant parts. Some others neglect disaster resistant standards because they have limited technical assistance on how to strengthen their homes. Overall, there is always a strong link between the non-application of disaster resistant measures and socio-economic issues and people's awareness.

In Da Nang, some households believe that building a disaster resistant house will cost them a considerable amount

out of their pockets. Some households are overconfident that Da Nang is never hit by big storms and, accordingly, they pay less attention to disaster preparedness. Others are inadequately aware of safe construction and thus want unsafe designs, such as lack of foundation or prefer awnings (ADPC, 2007). Some already realise potential dangers of storm, but do not follow storm resistant construction due to great pressures from family members or relatives who attempt to convince them to build bigger houses for additional functions rather than follow storm resistant standards (ADPC, 2007). A survey after Xangsane (2006) shows that most households, mainly low income, use supportive finance to build their homes in the same types of previously unsafe ones (ADPC, 2007), especially in the cases with no professional assistance. Some do not have enough money to reinforce their houses even when they are aware of its necessity. Most of surveyed households agreed that housing reinforcement for poor or low income households is necessary to build their resilience, improve their living conditions, and help them escape from poverty.

Many households reported that their houses were repaired or even rebuilt four to five times due to natural disasters (Norton and Chantry, 2008) and might be continued in next disasters if having no external assistance. It is a major setback, hindering economic development, impeding improvements of living conditions, healthcare, education, and productivity of disaster affected families and communities.

HOUSING VULNERABILITY IN DA NANG

Housing in Da Nang, especially the semi-permanent which covers higher percentages, still has many technical weaknesses in structure that may be easily destroyed by strong winds or typhoons. In the aftermath of a storm or typhoon, roof damage appears the most in semi-permanent houses which cause other damages of walls and doors or windows. In almost all cases, these homes are possible to reinforce or renovate for disaster resistance.



Semi-permanent houses in Da Nang (Ahmed, 2012)

Settlement

Buildings often have no protection from outside (such as windbreaks) or are designed in parallel planning, which create no obstructions to wind-flow.



Building Height

Houses with its height more than 3.6m are more vulnerable to storm and typhoon (CECI, 2003).



Duy et al., 2007

Building Shape

T-shape, L-shape and U-shape plans are more likely to be destroyed because these shapes create wind-suction bags during storm and typhoon (CECI, 2003; Duy et al., 2007). Long rectangular plans with the ratio between the length and width over 2.5 (Duy et al., 2007) are also vulnerable to storm and typhoon.



Roof Shape



Ahmed, 2012

Twin roof (gable roof) makes the gable walls directly exposed to winds (CECI, 2003).

Reversed twin roof according to the length of building create larger areas of gable walls, which are dangerously exposed to strong winds. This type is commonly appeared in suburb, peripheral or relocation zones of Da Nang city.



Twin roof creates two gables vulnerably exposed to strong winds.



Large gable walls exposed to strong winds.

Long Roof Eaves



CECI, 2008

Long roof eaves are easily destroyed by strong winds

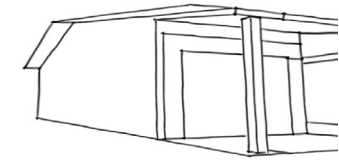

Roof angle

Most houses have their roofs, which are quite flat with roof angles smaller than 30° . This creates more wind pressure on roof during typhoon.

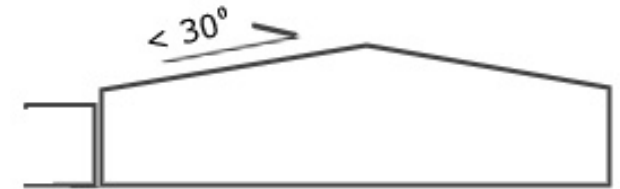

Lack of bond (or ring) beam on the top of surrounding walls



Tuan Anh, 2011

Bond (or ring) beam keeps surrounding walls stable during typhoon.

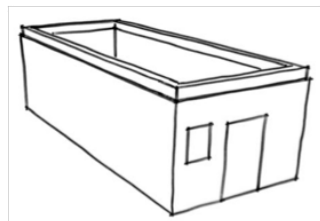

Lack of secure connections between roof frame and walls



Tuan Anh, 2011

No secure attachment to supporting walls beneath

Thin surrounding walls without strengthened elements:



Brick surrounding walls with thickness of 110mm is risky to wind force. Piers or pillar in-between at the distance of 2.5m should be added or replaced by thicker walls of 220mm (Duy et al., 2007).

To Left: (Tuan Anh, 2011)
Surrounding walls with thickness of 110mm are vulnerable to typhoons.

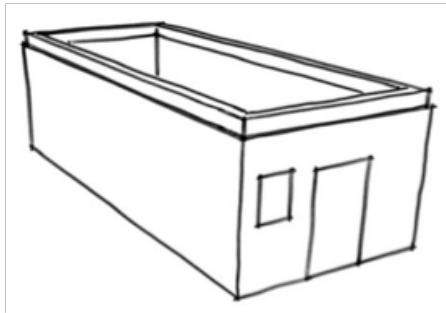

Long walls without consolidated partitions or piers



(CECI, 2008)

The long rectangular plan creates the long gable walls without any consolidated partitions or piers in-between to reduce wind effects is very vulnerable to typhoon (CECI, 2003).

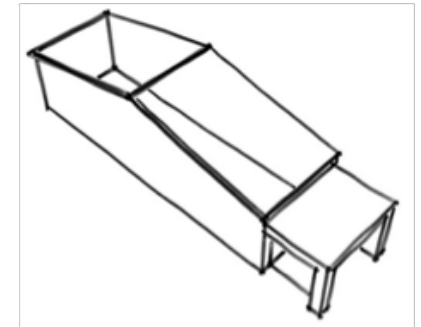

HOUSING GOVERNANCE AND FRAMEWORK

At the national level, there are two key documents addressing disaster risk reduction in all sectors of the country including housing through general guidelines and principles. The first document is the National Strategy for Natural Disaster Prevention, Response and Mitigation to 2020 released in 2007 with the key goal to minimise damage and loss of human life and property. The second one is the National Target Program to Respond to Climate Change released in 2008 with the focus on the issues related to climate change. These two documents highlight the importance of disaster mitigation measures for residential housing for disaster prone regions of the country, especially in the central Vietnam where flood and typhoon are appearing increasingly in their numbers and severity. However, these two national documents play the role as top-down direction for the promulgation of building codes and regulations at lower levels in provinces and cities. Thus, they view disaster risk reduction in macro terms without specific strategies or solutions for each sector or region. And of course, responsiveness to particularly local needs, local context and capacity for disaster resistant housing are inadequately addressed in these two documents.

In Da Nang, the city planning has taken measures of disaster risk reduction into consideration through building codes. For example, buildings close to the sea or river must have ground floor levels higher than the 100-year flood level, or trees have been planted at the coast to minimise storm-surge impacts. Building permits are required in urban areas of Da Nang and quickly granted to household if their house-floor area below 250m² and building height not more than two stories. This building permit is granted once building design is consistent with the city's Master Plan and architectural guidelines. For bigger houses with floor area over 250m² and higher than two stories, a double-check will occur before granting a building permit to ensure other criteria such as whether building is designed by registered architects and built by registered construction firms or not, whether its conformation to safety guidelines and standards have been met. In reality, the most vulnerable housing types

to natural disasters do not belong to this type of housing resulting in fewer checks against safety-related standards.

The other noticeable issue of housing governance in Da Nang that lead to a more vulnerable housing sector is the inadequate administration of local authorities (no policies or legal frameworks) to force people to follow safe construction practices apart from advising or encouraging them to do follow (ADPC, 2007).

THE COSTS AND BENEFITS

Housing reinforcement for disaster resistance always carries an additional cost of construction, low or high dependent on the level of resistance required for a given house. As mentioned before, various pressures have led to the missing of essential construction practices for disaster resistance, especially for low-income households. In addition, households often underestimate the cost of construction and then, in reality, it exceeds financial capacity of family. Their houses are then either stopped in the middle stages of construction with a lack of building parts (doors or windows) or they cut down the use of some costly materials (such as reducing the amount or the size of steel rods inside RC piers or ring beams). These are extremely unsafe conditions to natural disasters.

This requires an appropriate approach to provide low-income families with expected economic benefits in the light of disaster mitigation. This approach comprises not only financial assistance but also the professional support for safe reinforcement or construction. Expense for technical reinforcement of one unsafe house in disaster prone regions of central Vietnam, on average, covers about 15-30% of total construction cost (Huy, 2002). Sometimes it reaches 60% or more (Norton and Chantry, 2008) for extremely vulnerable homes, expected to withstand a storm up to level 12 of Beaufort scale.

If an unsafe house is not upgraded or renovated according to storm resistance, it might be repaired at least two times

each year due to annual typhoon visits. According to recent surveys, cost for a one time housing repair completed by owners translates to a minimum of 20% of total value of the repaired house. This is commonly experienced by medium and low income groups. For example, the average value of a house in rural areas of central Vietnam, which can be structurally renovated, is estimated at 25-30 million VND. If they do not follow disaster resistant designs, their owners will spend 10-12 million VND per year for repairing or replacing damaged items. In the five-year period for example, they spend at least double the cost of initial construction on only shelter repair and renovation and, in total, they invest 75-90 million VND for their housing construction and renovation over five years.

The lifespan of the house is expected to last for 15-30 years on average for semi-permanent ones, cost for housing repairs after disasters will significantly decrease while benefits for owners will gradually increase. It helps low income households have greater chances to enrich their savings for other development purposes of families. By this way, they are able to escape from poverty and reach a more stable and sustainable life.

References

1. ADPC 2007. Promoting Safer Housing Construction through CBDRM: Community-designed Safe Housing in Post-Xangsane Da Nang City. Safer Cities 19. Thailand.
2. AUDEFROY, J. F. 2010. Post-disaster emergency and reconstruction experiences in Asia and Latin America: an assessment. *Development in Practice*, 20, 664-677.
3. CECI 2003. COMMUNITY ADAPTATION FUND (CAF) OPERATIONAL MANUAL. Capacity Building for Adaptation to Climate Change project. Vietnam.
4. CECI & ADPC 2008. Manual for Housing Construction for basic Resistance to Flood and Storm Da Nang.
5. CU, N. H. 2008. TĂNG TRƯỞNG KINH TẾ Ở THÀNH PHỐ ĐÀ NẴNG, BỀN VỮNG HAY KHÔNG BỀN VỮNG?
6. (DA NANG'S ECONOMIC GROWTH IS STABLE OR NOT?). *Journal of Science and Technology*, 5, 125-134.
7. DAVIS, I. 1978. Shelter after Disaster, Oxford, Oxford Polytechnic Press.
8. DUY, T. C., XUAN, C. N., DAI, M. N., HUU, H. N. & TAT, C. B. 2007. Typhoons and technical solutions recommended for existing and new houses in the cyclonic regions in Vietnam. *Modern Design, Construction and Maintenance of Structures*. Hanoi, Vietnam.
9. ESTHER, C. 2011. Home, Sustainable Home. Making Cities Work. Australia: Paul Noonan.
10. FIEN, J., CHARLESWORTH, E., LEE, G., MORRIS, D., BAKER, D. & GRICE, T. 2008. Towards a design framework for remote Indigenous housing. Australian Housing and Urban Research Institute.
11. HUY, N. H. 2002. Risk Assessment and Management for a Sustained Shelter Delivery System in Vietnam. Workshop on Safer Shelter in Vietnam, 2002 Hanoi, Vietnam. Thailand: ADPC, 59-74.
12. IFRC, I. F. O. R. C. A. R. C. S. 2010. Risk Reduction: Framework on disaster risk reduction in South East Asia. Bangkok.
13. MONRE, M. O. N. R. A. E. 2008. National target program for climate change response. Hanoi: Vietnamese Government.
14. NHU, O. L., THUY, N. T. T., WILDERSPIN, I. & COULIER, M. 2011. A preliminary analysis of flood and storm disaster data in Vietnam. Ha Noi
15. NORTON, J. & CHANTRY, G. 2008. Vaccinate your Home against the Storm - Reducing Vulnerability in Vietnam. *Open House International*, 33, 26-31.
16. PHONG, T. & TINH, B. D. 2010. HOUSING SECTOR CONSIDERATIONS IN DISASTER RISK REDUCTION AND CLIMATE CHANGE ADAPTATION. Climate Change Adaptation and Disaster Risk Reduction: Issues and Challenges. Emerald Group Publishing Limited.
17. SUAREZ, P., SUANDERS, G., MENDLER, S., LEMAIRE, I., KAROL, J. & CURTIS, L. 2008. Climate-related Disasters: Humanitarian Challenges and Reconstruction Opportunities. *Climate Change and Place*, 20, 62-67.
18. VIETNAM-GOVERNMENT 2007. National Strategy for Natural Disaster Prevention, Response and Mitigation to 2020. Hanoi: Vietnamese Government.

Disclaimer

This document is an output from a project funded by the UK Department for International Development (DFID) and the Netherlands Directorate-General for International Cooperation (DGIS) for the benefit of developing countries. However, the views expressed and information contained in it are not necessarily those of or endorsed by DFID, DGIS or the entities managing the delivery of the Climate and Development Knowledge Network*, which can accept no responsibility or liability for such views, completeness or accuracy of the information or for any reliance placed on them.